

# SMART STEAM TRAP

MODEL  
**SVT**™  
DN 25

## Description

The SMART SVT™ DN 25 Venturi Steam Trap is designed for multipurpose applications from line drainage and trace heating, through small to large heat exchanger applications. The trap has an integrated bottom strainer and a removable venturi insert. The body of the steam trap does not have to be removed from the line for maintenance purposes. Access to the venturi insert and strainer is via the top and bottom caps. SMART SVT™ model steam trap comes with an integrated blowdown valve for periodic cleaning of the filter.

## Sizes and Connections

DN25 (1")

Threaded / Socket Weld/ Flanged

## Pressure / Temperature Limits

PMA (Maximum Allowable Pressure) 100 bar g (1450psi g)

TMA (Maximum Allowable Temperature) 400°C (750°F)

PMO (Maximum Operating Pressure) 62 bar g (1305 psi g)

## Optional Extras

Flanges to your specifications can be added to socket weld connection.

Closed bottom cap.

## Guarantee

20 year product guarantee as per standard terms and conditions.

## Benefits

1. No moving parts to fail
2. Stainless steel construction; 20 to 30 year lifetime
3. Wide range of capacities
4. 20 year performance and materials warranty
5. Permanent up to 20-30% energy reduction; 1-2 year ROI typical
6. Significant lifetime labor and material savings
7. High capacity integrated strainer
8. Bottom cap for easy access to strainer
9. Inverted nozzle to deflect blockages
10. Can be installed in any orientation
11. Replaceable venturi inserts for precise sizing
12. Supplied with sizing and engineering services
13. Steam trap tag loop



## CAPACITY CHART

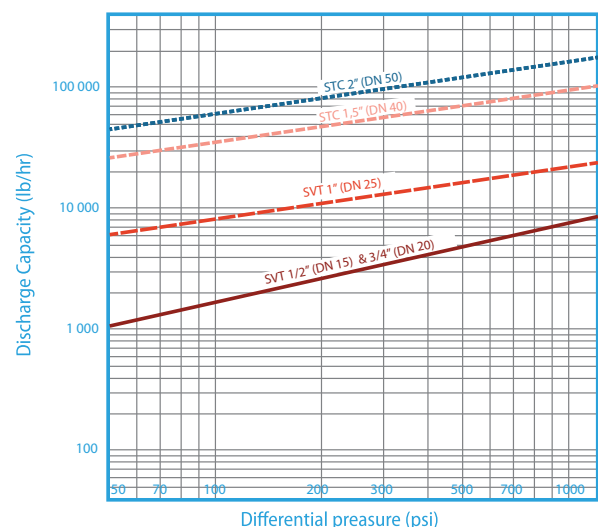

SMART Valves Inc.

USA Division: +1 833 775 7888

EU Division: +32 38081549

info@smartvalvesinc.com



SMART™  
VALVES

SMART STEAM TRAP™

RELIABILITY SIMPLICITY SUSTAINABILITY

# SMART STEAM TRAP

MODEL  
**SVT**™  
DN 25

## Assembly

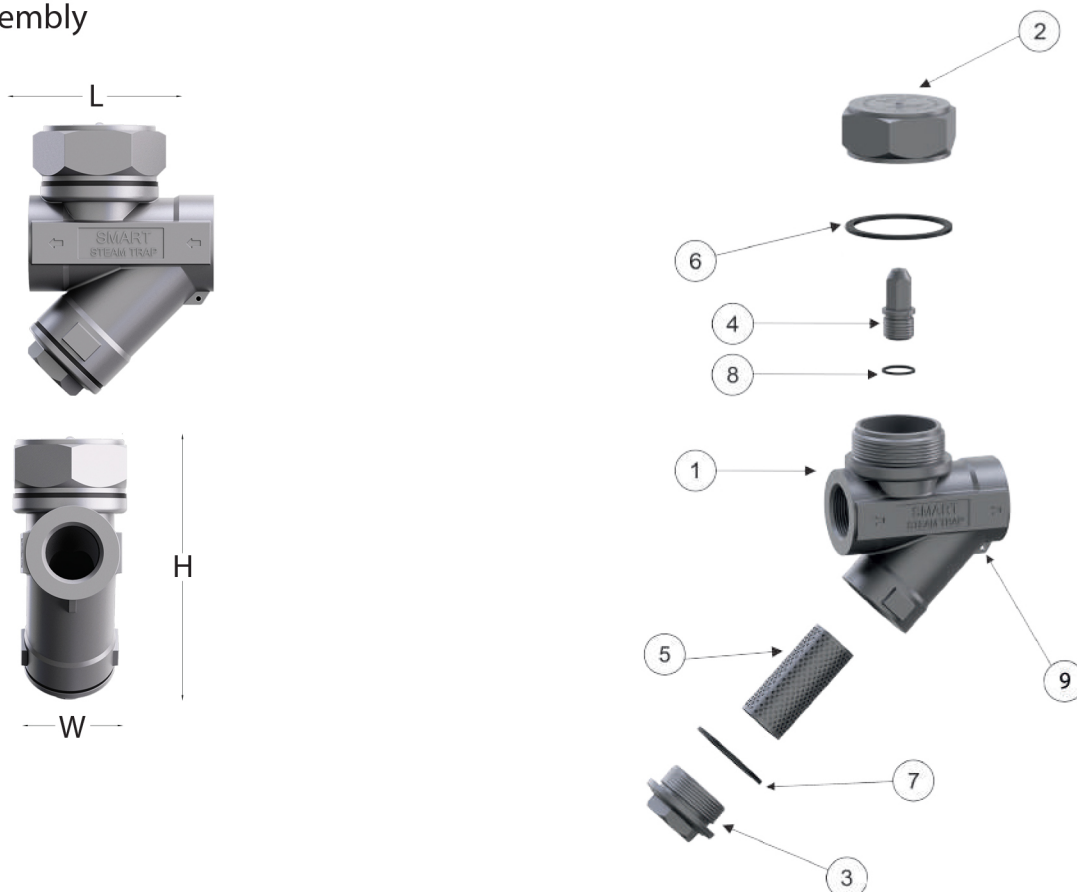

## Dimensions and Weights

Size	Connection	L	H	W	Weight
DN25 (1")	DN25 Threaded NPT / BSP / Socked Weld	3.74 in/99mm	5.63 in/143mm	2.13 in/55mm	5.07 lbs/2.3kg

## Material

1. Body	ASTM A351 - CF3M
2. Top Cap	ASTM A351 – CF3M
3. Strainer Cap	ASTM A351 – CF3M
4. Removable Venturi Insert	304 Stainless Steel
5. Strainer	316 Stainless Steel
6. Gasket	Graphite
7. Gasket	Graphite
8. Gasket	Paranite
9. Steam Trap Tag loop	

## Torque Settings

2. Top Cap	80 Nm
3. Bottom Cap	80 Nm
4. Removable Venturi Insert	10 Nm

\*In the interests of development and improvement of the product, we reserve the right to change the specification without notice.

SMART Valves Inc.

USA Division: +1 833 775 7888

EU Division: +32 38081549

info@smartvalvesinc.com



**SMART STEAM TRAP**™

RELIABILITY SIMPLICITY SUSTAINABILITY