

SMART STEAM TRAP

MODEL
SVT-F™
DN 15-DN 20

Description

The SMART SVT-F DN15/20 Flanged venturi steam trap is designed for multipurpose applications from mainline drainage and trace heating, through small to medium size heat-exchanger process applications. The trap has integrated strainers and a removable Venturi insert. The body of the steam trap does not have to be removed from the line for maintenance purposes. Access to the Venturi insert and both strainers is via the top and bottom caps. SVT model Steam traps come with an integrated blowdown valve for periodic cleaning of the filters.

Sizes and Connections

DN15 (½"), DN20 (¾")

Flanged

BS 4504, PN40 - PN100 and ASME B16.5, 300 - 1500

Additional flanges available upon request

Pressure / Temperature Limits

PMA (Maximum Allowable Pressure) 100 bar g (1450 psi g)

TMA (Maximum Allowable Temperature) 400°C (750°F)

PMO (Maximum Operating Pressure) 62 bar g (899 psi g)

Optional Extras

Can be customized per required F/F dimensions.

Guarantee

20 year product guarantee as per standard terms and conditions.

Benefits

1. No moving parts to fail
2. Stainless steel construction; 20 to 30 year lifetime
3. Wide range of capacities
4. 20 year performance and materials warranty
5. Permanent 20-30% energy reduction; 1-2 year ROI typical
6. Significant lifetime labor and material savings
7. Dual strainer system built-in
8. Top and bottom cap for easy access to strainers
9. Inverted nozzle to deflect blockages
10. Can be installed in any orientation
11. Supplied with sizing and engineering services
12. Replaceable Venturi inserts for precise sizing
13. Integrated blowdown valve for strainer cleaning



CAPACITY CHART

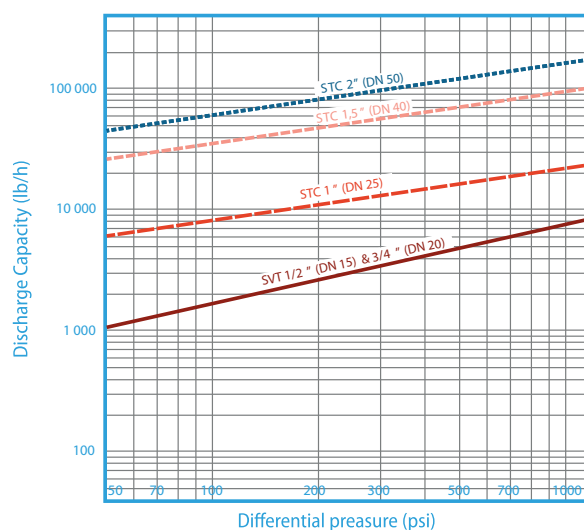

SMART Valves Inc.

USA Division: +1 833 775 7888

EU Division: +32 38081549

info@smartvalvesinc.com



SMART™
VALVES

SMART STEAM TRAP™

RELIABILITY SIMPLICITY SUSTAINABILITY

SMART STEAM TRAP

MODEL
SVT-F™
DN 15-DN 20

Assembly

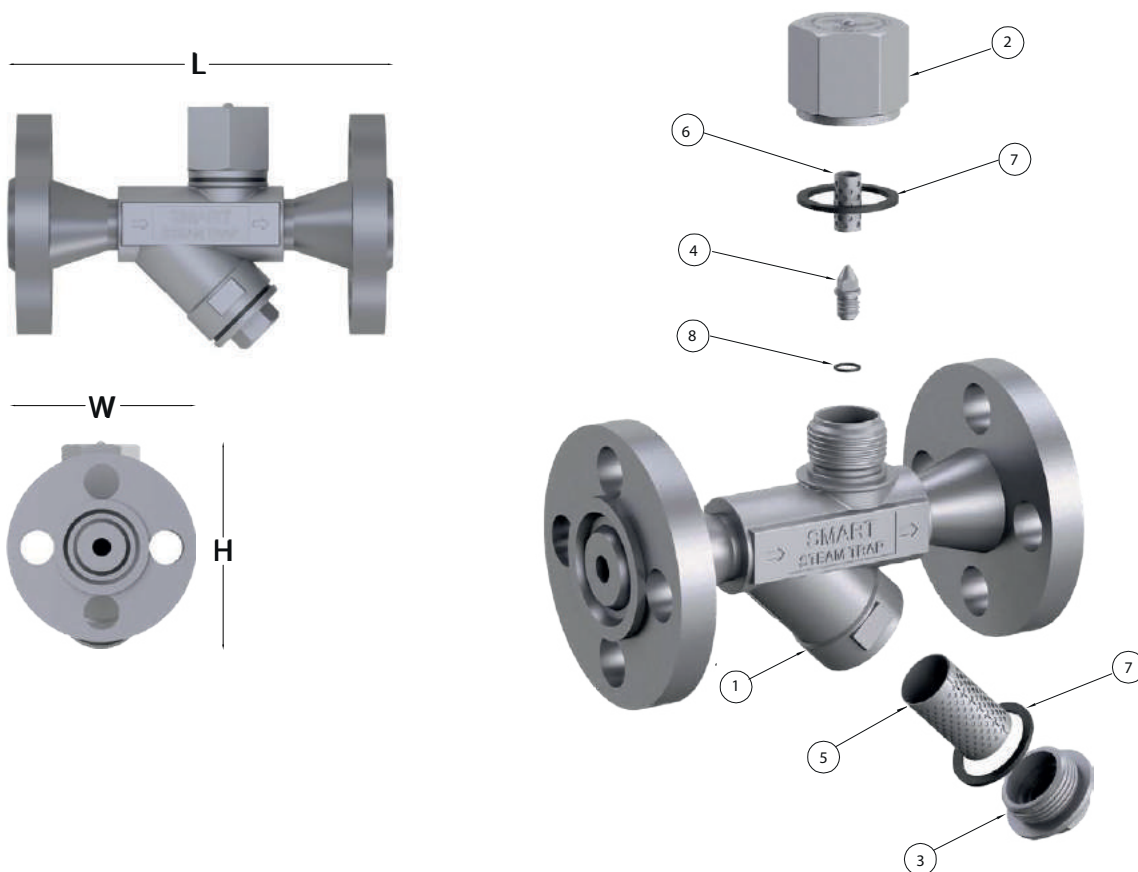

Dimensions and Weights

Size	Connection	L	H	W	Weight
DN15 (1/2") - DN20 (3/4")	Flanged	6.10 in /155 mm	4.49 in/114 mm	3.78 in/96 mm	5.51 lbs/2.5 kg

Material

1. Flanged Body	ASTM A351 – CF3M
2. Top Cap	ASTM A351 – CF3M
3. StrainerCap	ASTM A351 – CF3M
4. Removable Venturi Insert	304 Stainless Steel
5. Primary Strainer	316 Stainless Steel
6. Secondary Strainer	316 Stainless Steel
7. Gasket	Graphite
8. Venturi Insert Gasket	Paranite

Torque Settings

2. Top Cap	80 Nm
3. StrainerCap	80 Nm
4. Removable Venturi Insert	10 Nm

*In the interests of development and improvement of the product, we reserve the right to change the specification without notice.

SMART Valves Inc.

USA Division: +1 833 775 7888

EU Division: +32 38081549

info@smartvalvesinc.com



SMART™
VALVES

SMART STEAM TRAP™

RELIABILITY SIMPLICITY SUSTAINABILITY